

Office of the Controller General of Patents, Designs &
TradeMarks, Boudhik Sampada Bhavan
Antop Hill, S. M. Road, Mumbai - 400037

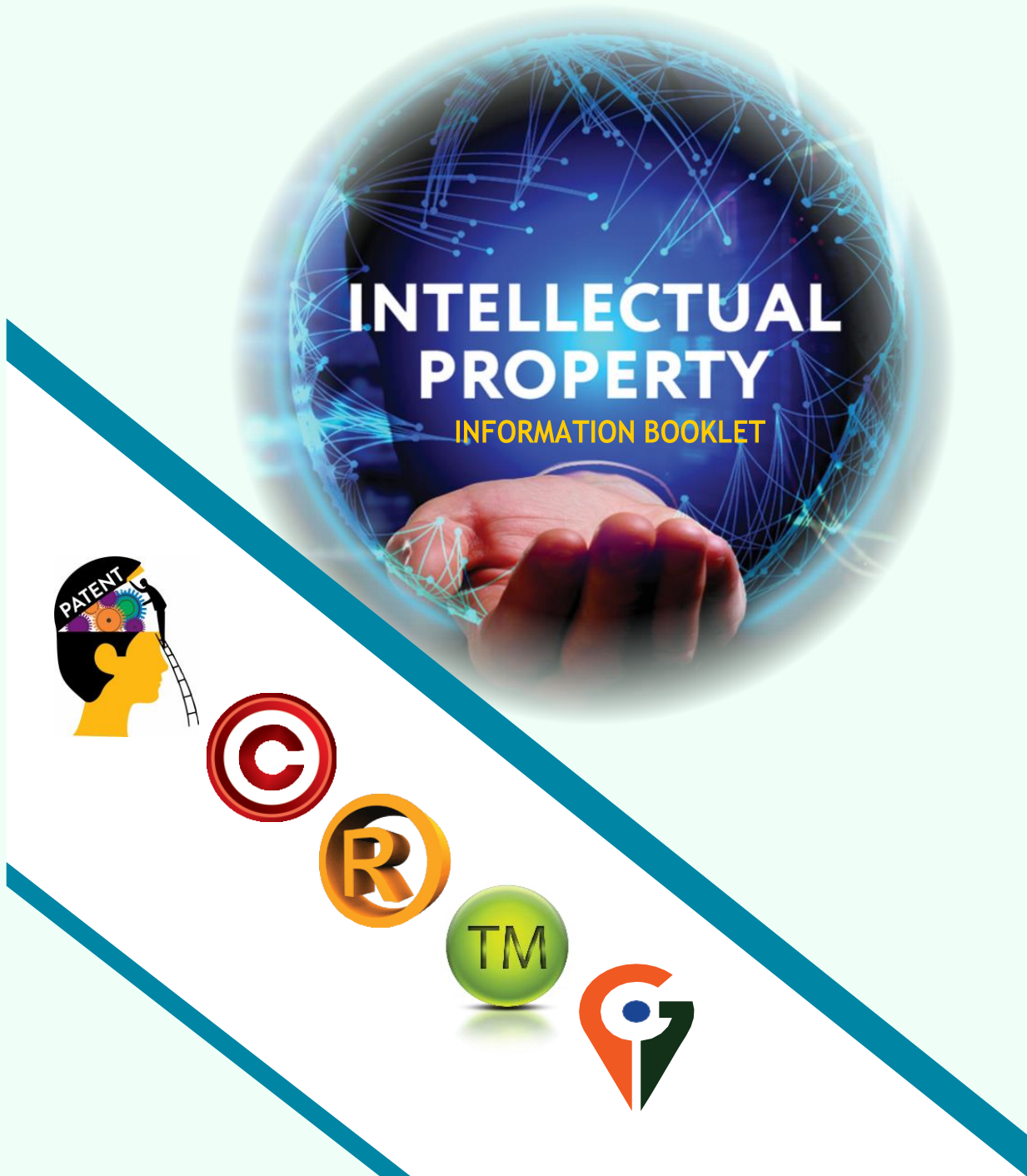

Disclaimer:-

The matter in information brochure is not exact reproduction of Act and Rules or any orders of Government. This material provided is introductory in nature and should not be produced as a matter of evidence or authenticity in any court of Law or anywhere. This office/department/institute is not responsible for result of any action taken neither on the basis of any material/PPT nor for any errors or omission. Suggestions for improvement of this material will be gratefully accepted.

INTRODUCTION TO INTELLECTUAL PROPERTY RIGHTS

CONCEPT OF INTELLECTUAL PROPERTY

Intellectual Property means the property represented by the product/process emanating from creativity of the human mind, human intellect and creative ideas. It can be an Invention, original Design, Trademarks, artistic creation etc. In earlier times, physical or tangible assets like movable and immovable properties fetched the maximum value and the owner had an exclusive right over it. With the passage of time, new ideas cropped in, new concepts and means for the progress of mankind were thought of & new inventions came to the forefront, which brought about industrial, economical and cultural development in the society.

These new activities acquired the form of intangible assets owing to the inherent and practical values associated with them. Therefore, another form of property right was generated which required safeguarding for the owners of those properties. The property right, pertaining to such intangible assets, is called Intellectual Property Rights, popularly known as IPR. It share many of the characteristics associated with conventional concept of the personal property.

The intellectual property is an asset and, as such, it can be bought, sold, mortgaged, licensed, exchanged or gratuitously given away like any other form of the property. Further, by acquiring a legal right over the property, the creator of the intellectual property seeks to ensure that he has exclusive right over it and that the property can be put to use by others only with his consent. Besides, ownership of Intellectual Property Right is the legal recognition and reward you receive for your creative efforts, in the context of global market scenario.

TYPES OF INTELLECTUAL PROPERTY RIGHTS

Intellectual Property Rights can be broadly divided into two categories: -

Intellectual Property

A] Industrial Property:-

Patents, Designs, Trademarks, Geographical Indications

B] Copyright:-

Copyright shall subsist throughout India in

- (a) Original literary, dramatic, musical and artistic works;
- (b) Cinematograph Films; and Sound Recordings

Industrial property mainly consists of Patents, Designs and Trade Marks and Geographical Indications.

- Patents are granted for inventions.
- Designs for creations determining the appearance of products/articles.
- The trademarks indicate the origin of goods or services and also enable customers to distinguish the goods and services of one trader from those of other, whereas

- Geographical Indication is issued for products that originate from a specific geographical area and possess characteristics, qualities or reputation that are due to that origin.
- Copyright relates to artistic and literary creation such as poem, novel, painting, computer software etc. In recent times, the term Intellectual Property is used to include other forms, such as, plant variety, integrated circuits etc.

PATENTS

Patent is an exclusive right granted by the Government to the applicant for his disclosed invention of industrial product or process which should be new, non-obvious, useful and patentable as per the patentability criteria laid down in the national law. A patent offers technical solution to a technical problem. In lieu of disclosure of invention, the Government provides legal protection to the inventions for a limited term for applicant's invention. Patents rights can be transfer from inventor to applicant via assignments. The Government gives the territorial right for the invention in the country where it is granted.

IMPORTANCE OF PATENT RIGHTS

- Patent right is granted for a limited period of time i.e. 20 years from the date of filing. It gives territorial right, exclusive right and can be enforced only in the country where it has been granted.
- The patent right may enables the patentee to derive material benefit, to which he/she is entitled, as a reward for his intellectual efforts and compensation / royalty for expenses incurred in research and experimentation relating to his invention.
- Patent right gives protection against infringement and creates possibility of assigning or licensing of the right and enables the patentee to take legal action against any person who is exploiting/infringing the patented invention without consent or license from the patentee. A patentee acquires the right, enforceable by law, to decide who shall use and who shall not use his patented invention. Patentee retains this right for the term of the patent provided applicant pays the necessary renewal fees.
- The grant of patent right by the government does not mean that the government itself would automatically enforce the patent right. It is up to the patentee/assignee to bring an action, usually under civil law, for any infringement of the patent right

Disclaimer: This is just information document, for details you can see through office website Various Documents required for Filing of ordinary Patent application in India (as per Patents Rules)

A) Forms - Details of all these forms are freely available on office website www.ipindia.gov.in All the fees given below are online/E-filing fees, if filed by hard copy then 10 % extra fees, further please see fee schedule in office website.

Forms	Fees for individual/Natural person(s) or Startups or Small entities or Educational institutions	Fees for Other(s), alone or with natural person(s) or Startup(s) or Small entities or educational institution(s)/ Company
Form 1 Application form with details of applicant, inventor, address etc.	Fees Rs. 1600/- Signature of inventor on form 1 i.e. para 12 OR separate deed of assignment (to be filed within 6 months from filing date) and send original form 1 by post	Rs. 8000/-
Form 2	Provisional Specification (PS) or Complete specification (CS) In case, PS is filed first then, CS shall be file within 12 months from the date of filing of PS.	
Form 3	Statement and undertaking – i.e. regarding foreign filing details, If not filed in other country then it may be NIL statement in form 3	
Form 5	No fee. Form 5 to be file at the time of filing of CS after PS	
Form 8 (Optional) Mention Inventor name on Patent certificate	Rs. 800	Rs. 4000
Form 9 (Optional) Request for Early publication	Rs. 2500	Rs. 12500
Form 18 Request for Examination to be filed within 48 months from filing /priority date whichever is earlier	Rs. 4000	Rs. 20000
Form 18A (Expedited examination)	Rs. 8000 (see eligibility in form)	Rs. 60000 (see eligibility in form)
	To file form 18 A , form 9 can be filed for early publication	
Power of Attorney (optional)	Form 26 on proper stamp paper is required in case the application is filed through a registered patent agent (details of electronic list of registered patent agents are available in www.ipindia.gov.in)	

* All forms shall be signed by the applicant / authorized registered patent agent List of patent agent <https://ipindiaservices.gov.in/Agentregister>

- B] Form 2- i.e. Contents of Provisional / Complete Specification (it may change as per requirement)
- 1) Title of Invention
 - 2) Field of invention
 - 3) Prior art and its drawbacks / problems / purpose (Compare prior art & present invention)
 - 4) Aims / Objectives of invention
 - 5) Summary / Statement of the invention
 - 6) Brief description of drawings (if any)
 - 7) Details of biological material, if it is used in specification [for details please see section 10(4) of Patent act & rule 9]
 - 8) Detailed description of the invention/working of invention with reference to drawings/charts (if any)
 - 9) Working examples for best method of the invention / explain each figure or each embodiment
 - 10) Advantages of Inventions / applications – utility
 - 11) Claim (s) - Most important part (claims are not required in case of provisional specification)
 - 12) Drawings (if any)
 - 13) Abstract of invention – (problem- solution in 150 words, with drawing, if any)
- C] If file physical then send all necessary forms by post to Patent office of respective jurisdiction. DD should be drawn in favor of “Controller of Patents”, Payable at respective office jurisdiction
- D] Various Free Patent Search sites such as,
- <https://ipindiaservices.gov.in/publicsearch>
 - <https://patents.google.com/>
 - https://worldwide.espacenet.com/advancedSearch?locale=en_EP
 - <http://appft.uspto.gov/netahtml/PTO/search-adv.html>
 - <https://www.lens.org/lens/search/patent/structured>

(there are other office websites, anyone can get it from internet)

INDUSTRIAL DESIGNS

Design means only the features of shape, configuration, pattern, ornament or composition of lines or colors.

- It must be applied to any article, whether two dimensional or three dimensional or in both forms, by any industrial process or means, which in the finished article appeal to and are judged solely by the eye.
- Such a design is registerable, provided it is new or original and not contrary to public order or morality or does not contain obscene or scandalous matter.

BENEFITS OF REGISTRATION OF INDUSTRIAL DESIGNS

- Registration of a design confers upon the registered proprietor the exclusive right to apply a design to the article in a class in which the design has been registered
- Industrial Designs are of great commercial value because design of the article can often be a unique selling point. When companies are competing at equal price and functionality, Design is the differential that matters for achieving market advantage and competitiveness.

DESIGNS IMPORTANT POINTS

- Design must be New or Original
- Design is for beautifying an article to attract consumer. Design must be applied to an article
- Design in finished article should appeal to eye means the design features must be noticeable in the finished article (E.g, Detergent powder cannot be judged)
- Article means any article of manufacture and any substance artificial, or partly artificial and partly natural: and includes any part of article capable of being made and sold separately

Examples of some Designs

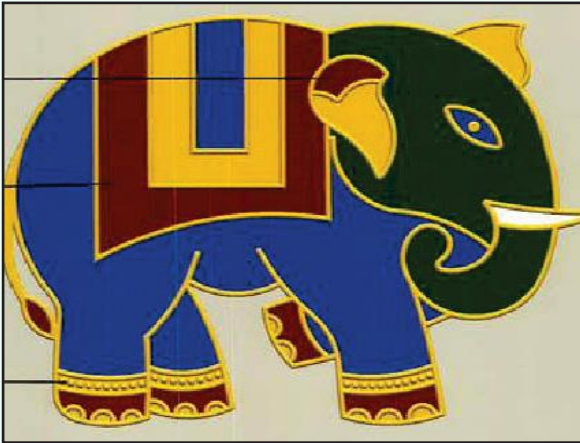

Decorative Article



Decorative Article



Cup-Dish SET

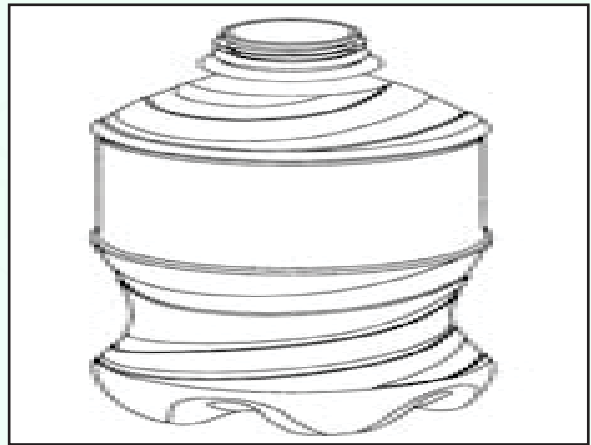

Bottle



Lid

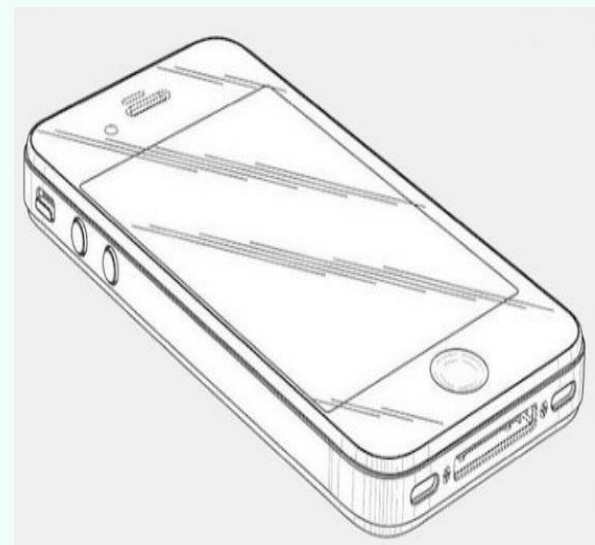

Mobile

Disclaimer: This document is informative, for details, Manual of Designs Practices and Procedures may be referred in the Official Website of CGPDTM. In the event of any disparity/conflict the provisions under The Designs Act, 2000 and The Designs Rules, 2001 as amended in 2021 and time to time amended shall prevail.

Documents Required for Filing of Ordinary Design Application (as per The Designs Amendment Rules 2021)

[A] Forms - Details & all these forms are available on office website www.ipindia.gov.in Below fees and forms are for Online/E-filing/physical filings. Detailed fee schedule is provided in the CGPDTM official website.

Forms	Fees for individual / natural person(s) and/ or Startup(s) and/ or Small entit(y)/(ies) and/ or Small entity	Fees for others, alone or with natural person(s) and/ or Startup(s) and/ or Small entity/ Company/ Institute/ other than natural person(s)
Form 1 Application form	Fees Rs. 1000	Rs. 4000
Representations [Sample of a representation sheet provided in next page]	Applicants full name, nationality, Address for service in India, Class no and sub class of Article, Name of the article, Signature of applicant OR Authorized person with date, with signature of applicant / Previous registration details (if any relevant with filed design)	
	Representation sheet shall be file at the time of filing of Form 1 Two sets of representation sheets A4 Size white durable Paper Sheet numbers to be mentioned in each sheet at top right side corner (total sheets). Best quality Photos / Designs/ line diagrams/ computer graphics of article representing various views of article (like perspective, top, bottom, side, front, back view etc.) Name of views Name of applicant shall be mentioned in top left corner Statement of novelty & Disclaimer in each set of representations Signature of applicant/ authorized person on representation sheets Disclaimers statement for mechanical or any other mechanism or any mode or principle of construction of article Disclaimers for trade mark(if any) Disclaimers for letters/words/ colors/ dotted lines etc. (if any) Disclaimer for extraneous matter if any appearing on photograph	
Form-21 Power of Attorney (if required)	Form-21(Power of authority/General Power of authority) in original (if filed through patent agent/advocates) (as in Schedule-II) If the applicant files copy of General Power of authority (GPA), it should be endorsed with the design application number, with which the original GPA has been filed on stamp paper (with appropriate stamp value depending on states as per The Stamp Act) is required.	
Form-24 (should be filed along with Form-1 if applicant is small entity)	Form-24 should always be accompanied with proper documentary evidence issued by competent Govt. Authority (like Udyog Aadhar registration certificate / certificate issued by DPIIT).	

All forms and representation sheets shall be signed by the applicant/ authorized registered patent agent/ Advocate

For preparation of representation sheets, Manual of Designs for Practice and Procedure may be referred. The applicant may refer the Check list available on www.ipindia.gov.in for list of documents required to be submitted while filing the application.

[C] Filing of design application - The applicant(s) have the option of filing design application at any Patent Office located at Mumbai, Delhi, Chennai, Kolkata [along with DD in favor of "Controller of Designs", Payable at Kolkata] or availing online filing facility on patent office website - www.ipindia.gov.in.

[D] Various Free Design Search sites (there are other offices sites also, anyone can access those from internet)

<https://ipindiaservices.gov.in/designsearch/> <https://www.google.com/imghp?hl=EN>

<https://euipo.europa.eu/ohimportal/en/rcd-search-availability>

<https://www3.wipo.int/designdb/en/index.jsp>

Name of the Applicant:\

XYZ.....

Total Sheet: 1

Sheet No: 1



PERSPECTIVE VIEW

The novelty resides in the shape, configuration and surface pattern of the BOTTLE as illustrated.

No claim is made by virtue of this registration in respect of any mechanical or other action of any mechanism whatsoever or in respect of any mode or principle of construction of the article.

No claim is made by virtue of this registration to any right to the exclusive use of the words, letters, numbers, logos, trademarks or extraneous matters appearing in the representation.

Dated.....

Signature

Name

TRADEMARKS

A Trade Mark is a word, name, logo, label etc., which indicate the origin of goods and services and enable customers to distinguish the goods and services of one trader from the goods of the other.

BENEFITS OF TRADEMARK

- When properly advertised, the Trade Mark becomes an effective instrument to attract the customers and acquire goodwill of the customer.
- A Trade Mark, through its widespread and extensive use in public, becomes popular and eventually results in acquiring an exclusive right, which can be legally enforced by the owner of the mark.
- Trade Mark helps the consumer to answer the question, "who makes the product or who has provided the service?" e.g. COCA COLA, SONY, TVS, etc.



COLLECTIVE MARKS:

These are the marks which distinguish the goods or services of members of an Association which is the proprietor TM from those of the others.

SERVICE MARKS:

When a Trade Mark is used in connection with services, it is called a "Service Mark". e.g. service like Hotels, restaurants, Airlines, Tourist agencies, Laundries and Cleaners etc.



CERTIFICATION TRADEMARKS:

These are the special kind of trademarks which indicate that the mark has been certified by the Proprietor of the mark as having certain characteristics like origin, ingredients, quality etc e.g. AGMARK, HALLMARK.



REGISTERABLE TRADEMARK:

- TM Should not belong to the class of Marks prohibited by Law e.g. Emblem of India as per the Emblems and Names (Prevention of Improper Use) Act, 1950
- TM Should not contain obscene matter and Should not hurt religious or sacred feelings of any citizen
- The existing trademarks registration is governed by The Trade Marks Act, 1999 & The Trade Marks Rules, 2017.

APPLICATION FORM: TM-A

Application Form: TM-A

- Mode of Filing: Application can be filed 'Online' utilizing comprehensive e-filing services available at <https://ipindiaonline.gov.in/> or 'offline' (A-4 size paper, typewritten or printed in Hindi or English)
- Half Application Fee is charged in case of Individuals/Startup/Small Enterprise. Further, 10% less fee is charged when filed online
- Prescribed Fee:
 - 1) For Individuals, Startups and Small Enterprises R. 5000/- (Rs. 4500/- if filed online)
 - 2) In all other cases Rs. 10000/- (Rs. 9000/- if filed online)
- Supporting documents: No supporting document required if applied in "proposed to be used status". However:
 - 1) In case the applicant claims to be Startups and Small Enterprises, it should always be supported by relevant supporting certificates issued by Government authority like certificate issued by DPIIT/ Certificate issued by Ministry of MSME (Udyam/ Udyog Aadhar Registration) etc.
 - 2) In case of Application being filed by an Agent, a copy of General Power of Authority is to be filed.
 - 3) In case the 'user' being claimed by the applicant, an Affidavit testifying to use along with supporting documents to be filed.

GEOGRAPHICAL INDICATION:

- Geographical Indication refers to any indication that identifies the goods as originating from a particular place, where a given quality, reputation or other characteristics of the goods is essentially attributable to its geographical origin. e.g., Darjeeling Tea, Basmati Rice, Kanchipuram silk, Nagpur oranges, Makrana marble, Blue Pottery of Jaipur, etc
- To ascertain whether product qualifies as a Geographical Indications? It should conform to five main parameters: 1. Originating from a particular Geographical Area; 2. Linkage with Geography and the product (Direct / Indirect); 3. Reputation of the Product (Local / National / International).; 4. Historical Origin; 5. Uniqueness and Quality of the product.
- In India, registration and protection of Geographical Indications is restricted to Goods only and Further “Goods” are divided into three main categories i.e., agricultural, natural and manufactured goods. Manufactured goods is further, sub-categories as Handicraft which includes Handloom, Textiles, goods of Industry or Industrial goods, food stuff & wines & spirits

BENEFITS OF GEOGRAPHICAL INDICATION:

- GI confers legal protection to geographical indications in India and prevents unauthorized use of a registered geographical indication by others.
- It boosts exports of Indian geographical indications by providing legal protection. It promotes economic prosperity of producers of goods produced in geographical territory.



REQUIREMENT FOR FILING OF GI APPLICATION

1. NAME OF GI

- To file logo of along with GI for better identification and Protection of GI Rights.

2. DETAILS OF APPLICANT:

- Name and Address of the Applicant
- Documentary evidence relating to legal status of a Association of Producers to be provided such as Memorandum and Articles of Association, Bye-laws, Registration certificates etc.,

3. NAME OF THE GOODS AND CLASS:

- As per Section (2) (1) (f) of G.I. Act 1999.
- Agricultural, Natural, Handicrafts, Industry, Manufactured goods & Food Stuffs
- Classification of Goods as per Schedule 4 mentioned in GI Act, 1999.

4. GI AREA: CERTIFIED COPY OF AREA MAP

- The GI area may be indicated by giving details of the longitude and latitude of the production area. The provided certified map (three copies) issued from a competent statutory authority giving details of the longitude and latitude of the production area.

5. AN AFFIDAVIT TO REPRESENT THE PRODUCERS

- The Applicant to file a notarized affidavit in original stating how the applicant claims to represent and safeguard/protect the interest of producers of proposed GI; Approximate Annual Turnover. The date, month & year of execution of the affidavit should be mentioned.

6. PROOF OF ORIGIN

- Brief description about the origin and the evolution of the GI.

Documentary evidence (such as gazetteers, published books & records) relating to proof of origin (historical proof) of product along with usage of Name of GI.

7. METHOD OF PRODUCTION:

- The general good practices of Production adopted by the producers in the GI Area to be provided.
- The specific standards of Quality and process of sequence of production along with the characteristics which make the product Unique to be provided

8. SPECIFICATION & DESCRIPTION

- Specification of GI product to be to be provided with detailed and clear characteristic and technical specification.

9. UNIQUENESS:

- Peculiar features that makes the GI different from other similar goods.
- The human skill of producer in making of this unique product to be provided.

10. PARTICULARS OF INSPECTION BODY

- The inspection structure should be strengthened with an independent Neutral agency to maintain the quality and regulating the use of Geographical Indications.



HOW TO APPLY?

- Application for registration of a GI should be in the prescribed form (GI-1A to 1D). Accompanied by the prescribed fee – Rs.5000/- Per Class.
- It must be made in triplicate along with three copies of a statement of case, accompanied by Additional Representations, certified copies of Map, documents in support of origin.

SIGNING OF THE GI APPLICATION

- GI Agent
- Association : Authorized Signatory
- Body corporate / Organisations / Authority:
- Chief executive, M.D, President, Secretary, or other Principle Officer.

FILING OF GI APPLICATION

- The Application for Registration of GI Application shall be filed with the Geographical Indications Registry, Intellectual Property Office Building, G.S.T. Road, Guindy, Chennai – 600 032.
- E-Filing service was started in March, 2015.

PROCEDURE

- Upon Filing of an Application, a preliminary Examination report is issued for compliance of deficiencies in the Applications as per the GI Act & Rules within One Month.
- Upon compliance to the Preliminary Examination Report.
- The Registrar constitutes a Consultative Group of not more than Seven members, chaired by him along with persons well versed in the subject matter to evaluate and ascertain the correctness of the particulars furnished in Applications and its supporting documents.
- The Applicant is called upon to make a presentation before the Consultative group and based on the recommendation by the Consultative group an Examination Report is issued to the Applicant, to comply within two months.
- Upon compliance, the Application is accepted, the Application proceeds for Publication in the Official Journal. It is made available for public to raise their objection.

During this time/ period, **Any person**, on an application to the Registrar along with the requisite fees can oppose the Registration. If the Application is not opposed and time for Opposition has expired, the GI Application is Registered from the date of making the Application and certificate of Registration is issued. The Registration of a GI shall be for ten years and can be renewed from time to time.

COPYRIGHTS

- Copyright is protection that covers published and unpublished literary, scientific and artistic work. Copyright relates to the exclusive right to do or authorize to do certain acts in relation to original literary, dramatic or musical work, artistic creations (paintings, photographs, work of architecture, artistic craftsmanship) cinematographic films, sound recording, software programme etc, provided such works are fixed in a tangible or material form.
- Copyright comes into existence as soon as the work is created and protects skill & labour employed by the creator in production of his work. The term varies according to the nature of the work.
- Copyright is not given for just an idea, but subsists only in the material form to which the ideas are translated or expressed.
- No copyright for a person who merely communicates his brilliant idea to an artist or play writer. The production i.e. the result of communication of the idea, is the copyright of a person, who has fixed the idea in a form. The author has no monopoly in the ideas or subject matter; others can produce the same result and can have a copyright provided they do it independently. It is a Bundle of Rights and can be exercised independently of each other.
- Unauthorized copying or reproduction of the author's work amounts to infringement. But, a fair dealing with the work for private uses i.e. study, research, review, criticism etc, without an intention of commercial gain is not an infringement.

The Copyright Act, 1957 (the 'Act') came into effect from January 1958. The Act has been amended five times since then, i.e., in 1983, 1984, 1992, 1994, 1999 and 2012. The main reasons for amendments to the Copyright Act, 1957 include to bring the Act in conformity with two WIPO internet treaties concluded in 1996 namely, the WIPO Copyright Treaty ("WCT") and WIPO Performances and Phonograms Treaty ("WPPT") to protect the Music and Film Industry and address its concerns; to address the concerns of the physically disabled and to protect the interests of the author of any work; Incidental changes; to remove operational facilities; and enforcement of rights. Some of the important amendments to the Copyright Act in 2012 are extension of copyright protection in the digital environment such as penalties for circumvention of technological protection measures and rights management information, and liability of internet service provider and introduction of statutory licenses for cover versions and broadcasting organizations; ensuring right to receive royalties for authors, and music composers, exclusive economic and moral rights to performers, equal membership rights in copyright societies for authors and other right owners and exception of copyrights for physically disabled to access any works.

Why should copyright be protected?

Copyright ensures certain minimum safeguards of the rights of authors over their creations, thereby protecting and rewarding creativity. Creativity being the keystone of progress, no civilized society can afford to ignore the basic requirement of encouraging the same. Economic and social development of a society is dependent on creativity. The protection provided by copyright to the efforts of writers, artists, designers, dramatists, musicians, architects and producers of sound recordings, cinematograph films and computer software, creates an atmosphere conducive to creativity, which induces them to create more and motivates others to create.

Is it not true that strict application of the principle of protection of copyright hampers economic and cultural development of the society?

Copyright laws are enacted with necessary exceptions and limitations to ensure that a balance is maintained between the interests of the creators and of the community.

To strike an appropriate and viable balance between the rights of the copyright owners and the interests of the society as a whole, there are exceptions in the law. Many types of exploitation of work which are for social purposes such as education, religious ceremonies, and so on are exempted from the operation of the rights granted in the Act. Copyright in a work is considered as infringed only if a substantial part is made use of unauthorisedly. What is 'substantial' varies from case to case. More often than not, it is a matter of quality rather than quantity. For example, if a lyricist copy a very catching phrase from another lyricist's song, there is likely to be infringement even if that phrase is very short.

Does the law allow any use of a work without permission of the owner of the copyright, and, if so, which are they?

Subject to certain conditions, a fair deal for research, study, criticism, review and news reporting, as well as use of works in library and schools and in the legislatures, is permitted without specific permission of the copyright owners. In order to protect the interests of users, some exemptions have been prescribed in respect of specific uses of works enjoying copyright. Some of the exemptions are the uses of the work

- i. for the purpose of research or private study,
- ii. for criticism or review,
- iii. for reporting current events,
- iv. in connection with judicial proceeding,
- v. performance by an amateur club or society if the performance is given to a non-paying audience, and
- vi. the making of sound recordings of literary, dramatic or musical works under certain conditions.

What is the scope of protection in the Copyright Act, 1957?

The Copyright Act, 1957 protects original literary, dramatic, musical and artistic works and cinematograph films and sound recordings from unauthorised uses. Unlike the case with patents, copyright protects the expressions and not the ideas. There is no copyright in an idea.

Does copyright apply to titles and names?

Copyright does not ordinarily protect titles by themselves or names, short word combinations, slogans, short phrases, methods, plots or factual information. Copyright does not protect ideas or concepts. To get the protection of copyright a work must be original.

Disclaimer: This is just information document, for details you can see through office website, act or rules and Copyright office manuals.

A] Forms – Details & all these forms and Fees are available on office website www.copyright.gov.in.

FORM XIV :- For Application for Registration of Copyright

Fees :- FEE CAN BE PAID BY POSTAL ODER /DEMAND DRAFT/ONLINE PAYMENT PAYABLE TO “REGISTRAR OF COPYRIGHTS, NEW DELHI”:

S.No.	For an application for COMPULSORY LICENSE :	Fee
1.	For a license to republish a Literary, Dramatic, Musical or Artistic work (Sections 31, 31A,31B* and 32A)	Rs. 5,000/- per work
2.	For a license to communicate an any work to the public by Broadcast(Section 31(1)(b))	Rs. 40,000/- per applicant/per sataton
3.	For license to republish a Cinematograph Film (Section 31)	Rs. 15,000/- per work
4.	For a license to republish a sound recording (Section 31)	Rs. 10,000/- per work
5.	For a license to perform any work in public (Section 31)	Rs. 5,000/- per work
6.	For a license to publish or communicate to the public the work or translation (Section 31A)	Rs. 5,000/- per work
7.	For a license to publish any work in any format useful for person with disability (Section 31 B)	Rs. 2,000/- per work
8.	For an application for a license to produce and publish a translation of a Literary or Dramatic work in any Language (Section 32 & 32-A)	Rs. 5,000/- per work
9.	For an application for registration or copyright in a:	
	(a)Literary, Dramatic, Musical or Artistic work	Rs. 500/- per work
	(b)Provided that in respect of a Literary or Artistic work which is used or is capable of being used in relation to any goods or services (Section 45)	Rs. 2,000/- per work
10.	For an application for change in particulars of copyright entered in the Register of Copyrights in respect of a:	
	(a)Literary, Dramatic, Musical or Artistic work	Rs. 200/- per work
	(b)Provided that in respect of a literary or Artistic work which is used or is capable of being used in relation to any goods or services (Section 45)	Rs. 1,000/- per work
11.	For an application for registration of Copyright in a Cinematograph Film (Section 45)	Rs. 5,000/- per work
12.	For an application for registration of change in particulars of copyright entered in the Register of Copyrights in respect of Cinematograph film (Section 45)	Rs. 2,000/- per work
13.	For an application for registration of copyright in a Sound Recording (Section 45)	Rs. 2,000/- per work
14.	For an application for registration of changes in particulars of copyright entered in the Register of Copyrights in respect of Sound Recording (Section 45)	Rs. 1,000/- per work
15.	For taking extracts from the indexes (Section 47)	Rs. 500/- per work
16.	For taking extracts from the Register of Copyrights (Section 47).	Rs. 500/- per work
17.	For a certified copy of an extract from the Register of Copyrights of the indexes (Section 47)	Rs. 500/- per copy
18.	For a certified copy of any other public document in the custody of the Register of Copyright or Secretary of the Copyright Board	Rs. 500/- per Copy
19.	For an application for prevention of importation of infringing copies (Section 53) per place of entry	Rs. 1,200/- per work

FORM XIV

Application for Registration of Copyright
[See rule 70]

To,

The Registrar of Copyrights,
Copyright Office,
Boudhik Sampada Bhawan, Plot No. 32,
Sector 14, Dwarka, New Delhi-110078
Phone: 011-28032496

Sir,

In accordance with section 45 of the Copyright Act, 1957 (14 of 1957), I hereby apply for registration of copyright and request that entries may be made in the Register of Copyrights as in the enclosed statement of Particulars' sent herewith.

1. I also send herewith duly completed the statement of further particulars relating to the work.
2. In accordance with rule 70 of the Copyright Rules, 2013, I have sent by pre-paid registered post copies of this letter and of the enclosed statement(s) to the other parties concerned, as shown below:

Names and addresses of the parties	Date of Dispatch
1	2

3. The prescribed fee has been paid, as per details below:
4. Communications on this subject may be addressed to:
5. I hereby declare that to the best of my knowledge and belief, no person, other than to whom a notice has been sent as per paragraph 2 above has any claim or interest or dispute to my copyright of this work or to its use by me.
6. I hereby verify that the particulars given in this Form and the Statement of Particulars and Statements of Further Particulars are true to the best of my knowledge, belief and information and nothing has been concealed therefrom.
7. List of enclosures:

Yours faithfully,

(Signature of the Applicant)

Place:

Date:

STATEMENT OF PARTICULARS

1.	Registration number <i>(To be filled in the Copyright Office)</i>	
2.	Name, Phone, Email, Address and Nationality of the Applicant	
3.	Nature of the applicant's interest in the copyright of the work	
4.	Class and description of the work	
5.	Title of the work	
6.	Language of the work	
7.	Name, address and nationality of the author and, if the author is deceased, the date of his decease	
8.	Whether work is Published or Unpublished	
9.	Year and country of first publication and name, address and nationality of the publishers	
10.	Years and countries of subsequent publications, if any, and names, addresses and nationalities of the publisher	
11.	Names, address and nationalities of the owners of the various rights comprising the copyright in the work and the extent of rights held by each, together with particulars of assignment and licenses, if any	
12.	Names, addresses and nationalities of other persons, if any, authorized to assign or license the rights comprising the copyright	
13.	If the work is an "artistic work", the location of the original work, including name, address and nationality of the person in possession of the work. (In the case of an architectural work, the year of completion of the work should also be shown)	
14.	If the work is an 'artistic work' which is used or is capable of being used in relation to any goods or services, the application shall include a certificate from the Registrar of Trade Marks in terms of the proviso to sub-section (1) of section 45 of the Copyright Act, 1957.]	
15.	If the work is an "artistic work" whether it is registered under the Designs Act 2000. If yes give details.	
16.	If the work is an "artistic work" capable of being registered as a design under the Designs Act 2000, whether it has been applied to an article through an industrial process and , if yes, the number of times it is reproduced.	
17.	Remarks, if any	

Place:

Date:

(Signature of the Applicant)

STATEMENT OF FURTHER PARTICULARS
(For Literary, including Software, Dramatic, Musical and Artistic Works only)

1.	Is the work to be registered	
(a)	An original work?	
(b)	Translation of a work in the public domain?	
(c)	A translation of a work in which copyright subsists?	
(d)	An adaptation of a work in the public domain?	
(e)	An adaptation of a work in which copyright subsists?	
2.	If the work is a translation or adaptation of a work in which copyright subsists:	
(a)	Title of the original work.	
(b)	Language of the original work.	
(c)	Name, address and nationality of the author of the original work and, if the author is deceased, the date of his decease.	
(d)	Name, address and nationality of the publisher, if any, of the original work.	
(e)	Particulars of the authorization for a translation or adaptation including the name, address and nationality of the party authorizing.	
3.	Remarks, if any.	

Place:

Date:

(Signature of the Applicant)

GENERAL INSTRUCTIONS

1. Rule 70 (3) of the copyright Rules 2013 provides that application has to be signed by applicant (author/owner) only it does not provide for an attorney to sign an application (Form XIV) including the Statement of Particulars (SoP) and the Statement of Further Particulars (SoFP) on behalf of the applicant, which are to be signed by none other than the applicant himself.
2. Form XIV, SoP & SoFP submitted only in the format prescribed by the Copyright Office. Only one copy of Form XIV, SoP & SoFP is required.
3. Name/address/nationality of the person whose photograph appears on the work may please be intimated in the remarks column. If that person is other than the applicant, a No Objection Certificate, in original may be obtained from that person [from heir(s) if the person is deceased/from the guardian in the case of minor] and enclose with the application.
4. Work should be identical with the Search Certificate in respect of size/colour/design.
5. As per the Rule 70 (5) for registration of Computer Programme or Software, the applicant should provide source code and object code.
6. In case of Sound Recording & Cinematograph category enclose the copy of agreement. If no agreement is made please obtain NOC from various copyright holders and enclosed the same with the application.
7. Power of Attorney should be on stamp paper duly accepted by attorney/signed by the applicant. Incomplete POA is not acceptable.

INSTRUCTIONS FOR FILLING UP THE COPYRIGHT REGISTRATION FORM:

FORM XIV

2. Indicate Names and addresses of the other parties concerned and date of dispatch.

Under Rule 70 (9) of the Copyright Rules, 2013, the applicant is required to send notice by registered post copies of Form XIV, SoP & SoFP to other parties concerned that you are submitting application for the registration of copyright in the Copyright Office. (Please see Cols. 7, 11, 12, 13).

3. The prescribed fee has been paid, as per details below: Please give the details of fee as shown below:

S. No.	DD/Banker's Cheque	Date	Amount	Name of the Bank

4. **Communications on this subject may be addressed to:** Please provide name and complete communication address with pin code. Pin code should be complete.

STATEMENT OF PARTICULARS

1. Registration number: (To be filled in the Copyright Office)
2. Name, Address and Nationality of the Applicant: Applicant may be individual/firm/company/government/university/institution. Also give the complete address and nationality.
3. Nature of the applicant's interest in the copyright of the work: Applicant may be Author/Owner/Publisher/Composer/Producer/Artist.
4. Class and description of the work: Please indicate the appropriate class of work from the following categories: Literary / Artistic / Cinematograph Film / Sound Recording / Music / Computer Software
5. Title of the work: Please mention the title of the work. The work to be registered for copyright must have a title which should be short and identical with the work.
6. Language of the work: Mention all the languages used in the work. In the absence of any script in the work, indicate 'nil'. In case of Computer Software please mention software language instead of 'English'.
7. Name, address and nationality of the author and, if the author is deceased, the date of his decease: Please furnish Name/Address/Nationality of the author. Here 'Author' means person(s) who has/have actually created the work. Authors may be more than one.

The Firm itself cannot be the author of a work except in case of Cinematograph Film and Sound Recording category.

If the author of the work is other than the applicant, a No Objection Certificate, in original from the author(s) (clearly indicating that he has no objection if the copyright in the work is registered in the name of the applicant) should be submitted. In case the author is partner/proprietor/employee of the applicant firm, the same may be indicated in the application.

If the author is deceased, please mention the date of decease and also submit a notarized affidavit regarding inheritance of right(s) /NOC from all the legal heirs of the deceased author in favour of the applicant

8. Whether work is Published or Unpublished: Mention whether the work is published or unpublished.
9. Year and country of first publication and name, address and nationality of the publishers: If the work is published, indicated the year/country of first publication/ name/ address/ nationality of the publisher(s).

If the work is published by a person/firm other than the applicant, a No Objection Certificate, in original, may be obtained from that person/firm and enclose with application.

10. Years and countries of subsequent publications, if any, and names, addresses and nationalities of the publisher: If the work has an any subsequent publications, indicated the year/country of first publication/name/address/nationality of the publisher(s).

11. Names, address and nationalities of the owners of the various rights comprising the Copyright in the work and the extent of rights held by each, together with particulars of assignment and licenses, if any: The name, address & nationality of the person(s) who hold(s) the various rights comprising the copyright in the work are required to be mentioned. In case the applicant himself intends to hold all the rights in the work, his particulars as already given against Col.2 may be mentioned. In case the applicant is a partnership firm, the names of all the partners and their respective shares in the copyright may be indicated.

12. Names, addresses and nationalities of other persons, if any, authorized to assign or license the rights comprising the copyright: If the author intends to authorize other person(s) to assign or license the copyright on his behalf, the name, address and nationality of such person may be indicated. If not, please indicate 'nil' against this column.

13. If the work is an "artistic work", the location of the original work, including name, address and nationality of the person in possession of the work. (In the case of an architectural work, the year of completion of the work should also be shown):

14. If the work is an 'artistic work' which is used or is capable of being used in relation to any goods or services, the application shall include a certificate from the Registrar of Trade Marks in terms of the proviso to sub-section (1) of section 45 of the Copyright Act, 1957.]: As per Rule 70 (6) a Search Certificate from The Trade Marks Registry is mandatory if the artistic work is to be used or capable of being used in relation to any goods, irrespective of whether trade mark is registered or not. Otherwise, clearly state that the work is neither used nor capable of being used in relation to any goods.

15. If the work is an "artistic work" whether it is registered under the Designs Act 2000. If yes give details:

16. If the work is an "artistic work" capable of being registered as a design under the Designs Act 2000, whether it has been applied to an article through an industrial process and , if yes, the number of times it is reproduced:

17. Remarks, if any: If any other information related to work to be registered, may be indicated in this column.

STATEMENT OF FURTHER PARTICULARS

If the work is original, answer to Col.1 (a) would be "yes", and all other columns may be indicated as "Nil". If the work is not original please furnish necessary details as required.

SICLD

Disclaimer: This is just information document; for details please visit office website, Act and Rules. Various Documents required for Filing of an SICLD Application (as per provisions)

A] Forms – Only some forms' details are given. All the forms are freely available on office website:
www.sicldr.gov.in

All the fees given are online/ physical fees

Form No.	Title	Fee
LD-1	Application for registration of layout-design (including Drawings/Photograph/GDSII file)	5000/-
LD-2	Notice of Opposition to Application for Registration of Layout-Design	500/-
LD3	Form of Counter-Statement	500/-
LD-4	Notice of intention to attend hearing	500/-
LD-6	Request for clerical error or for amendment	300/-
LD-12	Application for the rectification of the register	2000/-
LD-13	Application for registration of registered user	3000/-
LD-24	Application for review of Registrar's decision	1500/-
LD-30	Application for extension of time for giving notice of opposition	500/-
LD-32	Form of authorisation of agent in a matter or proceeding under the Act	-
LD-33	Notice for cancellation of registration of a layout-design or of assignment or transmission relating thereto	2000/-

All forms shall be signed by the applicant / authorized registered agent.

Intellectual Property India, Boudhik Sampada Bhawan, Plot No.
32, Sector 14, Dwarka, New Delhi-110078 Phone: +91-11-
25300207, 011 - 28034315

SIC Layout-Design

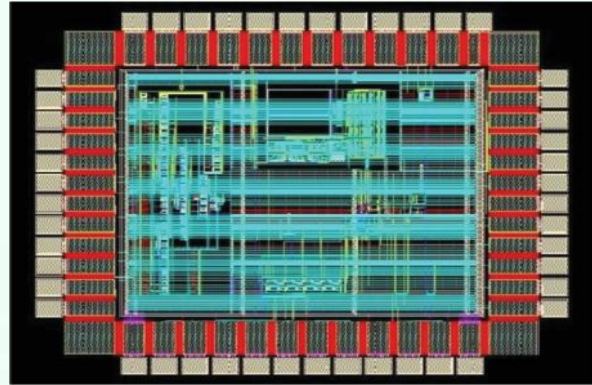
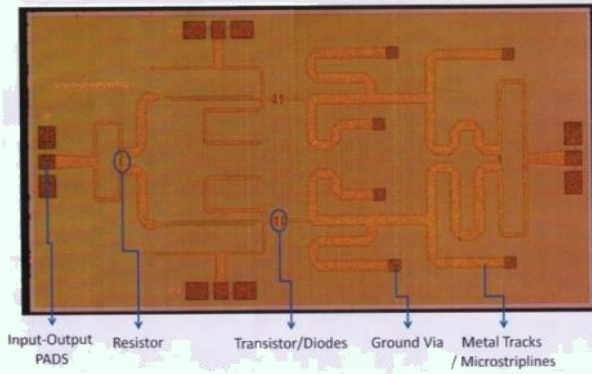

Applications and use

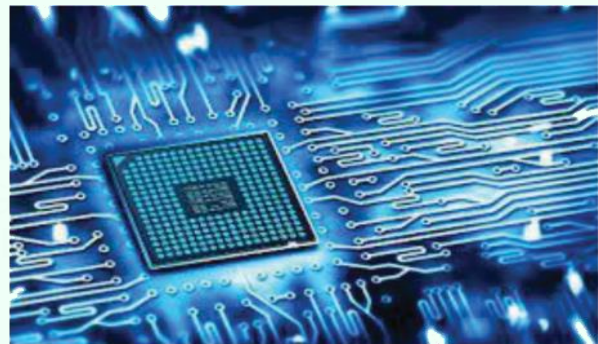

SICs: Basis of advanced electrical, electronics and IT related technologies

PATENTS/DESIGNS

- MUMBAI -

Intellectual Property India
Boudhik Sampada Bhavan
Antop Hill, S.M. Road, Mumbai-400037
Phone: 022-24132735 | 022-24123322
Email: mumbai-patent@nic.in

- DELHI -

Intellectual Property India
Boudhik Sampada BhawanPlot
No. 32, Sector 14, Dwarka, New
Delhi-110078
Phone: +91-11-25300207, 011 - 28034315
Email: nrmeena.ipo@nic.in

- KOLKATA -

Intellectual Property India Boudhik
Sampada Bhawan
CP-2 Sector V, Salt Lake City, Kolkata-700091
Phone: 033-23671987, 033-23679101, 033-
23671943, 033-23671944, 033-23671945,
033-23675090, 033-23675093,
033-23676685 | 033-23677320 |
Fax: 033-23671988
Email: kolkata-patent@nic.in | Email : controllerdesign.ipo@nic.in

- CHENNAI -

Intellectual Property India
Boudhik Sampada Bhawan
G.S.T. Road, Guindy, Chennai-600032
Phone: 044-22505242 Fax:
044-22502066
Email: chennai-patent@nic.in

TRADEMARKS

- MUMBAI -

Trademark Registry OfficeBoudhik
Sampada Bhavan
Antop Hill, S.M. Road, Mumbai-400037
Phone: 022-24101148 | 022-2410808 | Email: mumbai.tmr@nic.in

- NEW DELHI -

Trademark Registry OfficeBoudhik
Sampada Bhavan
Plot No. 32, Sector 14, Dwarka, New Delhi-110078
Phone: 011-28032406/100, 011-28032382 | Email: hodel.tmr@nic.in

- KOLKATA -

Trademark Registry Office
Nizam Palace, 2nd MSO Building, 7th Floor, 234/4,AJC
Bose Road, Kolkata-700020
Phone: 033-22905977 | Email: debanjan.c@nic.in

- CHENNAI -

Trademark Registry OfficeBoudhik
Sampada Bhavan
G.S.T. Road, Guindy, Chennai-600032
Phone: 044-22505200 (Ext. 311)
Email: tmrchennai@nic.in

- AHMEDABAD -

Trademark Registry OfficeBoudhik
Sampada Bhavan
Near Chanakyapuri overbridge, Besides AMC City
Civic Centre, Ghatlodia, Ahmedabad - 380061
Phone: 079-27601782 | Fax: 079-27601779
Email: ahmedabad.tmr@nic.in

COPYRIGHTS

- DELHI -

Copyright Office Boudhik
Sampada Bhawan
Plot No. 32, Sector 14, Dwarka, New Delhi-110078
Phone: 011-28032491 Fax: 011-28034301
Email: registrar.copyrights@gov.in

GEOGRAPHICAL INDICATIONS

- CHENNAI -

Geographical Indications Registry
Boudhik Sampada Bhawan
G.S.T. Road, Guindy, Chennai-600032
Phone: 044- 22502092 | Fax: 044-22502090
Email: gir-ipo@nic.in, mm.habibulla@nic.in

RGNIIPM - TRAINING

- NAGPUR -

Rajiv Gandhi National Institute of Intellectual Property Management
03, Hislop College Road, Civil lines, Near
Nagpur University, Nagpur, MH - 440001
Phone: 0712-2540916 / 0712 - 2540920 | Fax: 0712 - 2542955
Email: rgniipm.ipo@nic.in

HELPDESK NUMBERS

- The incoming board lines for O/o CGPDTM, Patent Office & Trademark Office Mumbai are: 022-24141026, 022-24112211, 022-24159192 & 022-24159194.
- Help Desk for Patent Office, Mumbai (All inquiries relating to Patent Office, Mumbai): 022-24156395, 022-24159192 Ext. 291, 022-24159194 Ext.291
- Help Desk for Trademarks (Inquiry and Information): 033 - 22905978
- Trademark Office: +91-11-28032406/382
- Online Services Support (e-filing):
(i) Trade Marks: +91-22-24132299, Email: tmr-helpdesk@nic.in and (ii) Patents: +91-11-25301243,+91-11-25300201,+91-11-28089556 Email: ipo-helpdesk@nic.in